

Solder Contacts

- Slide the rear accessories over the wire bundle in the proper sequence for re-assembly: cable clamp and/or endbell first, then ferrule and (if used) coupling nut.
- Insert individual wires through the proper holes in the grommet. Use isopropyl alcohol as a lubricant.
- Solder wires to appropriate contacts on the rear of the connector. ITT Cannon document RPI234 covers standard soldering practices and is available upon request by fax or mail. Please call.
- Fixture the connector for reassembly using the endbell assembly tools on page 266.
- Slide the grommet down the wires (lubricating the grommet with isopropyl alcohol will help).
- Fill all unused grommet cavities with a wire hole filler to maintain the sealing integrity of the connector. page 103.
- Slide coupling nut, ferrule, and endbell accessories over rear of the connector and tighten. For tooling see page 266.

Crimp Tool Operation

Hand Crimp Tool

NOTE: Hand crimp tools can be used with size 16S, 16 & 12 contacts. Size 8, 4 and 0 contacts require the use of air powered crimp tools. Call us for assistance in the use of these tools.

- Strip the wires to the appropriate length. See strip lengths on the Contact Selection Guide, page 103.
- Open the 192990-2050 crimp tool by squeezing the handles. Push the latch on 995-0002-052 turret to pop up the locator. Attach the turret to the crimp tool using the two captive hex bolts in the turret.

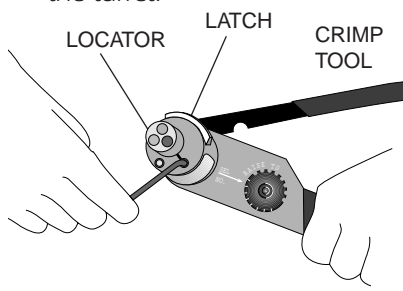

- Select the proper locator position for your contact by rotating the locator until the proper color is aligned with the index mark. Push locator back down until it snaps into position.

CONTACT SIZE	PIN LOCATOR COLOR	SOCKET LOCATOR COLOR
16S	Blue	Blue
16	Green	Red
12	Red	Red

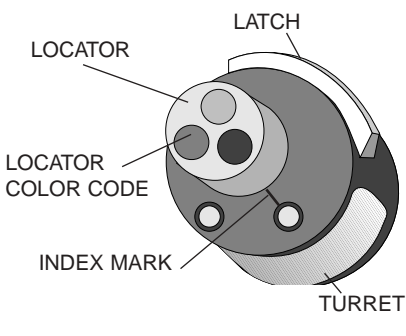

- Adjust dial for proper wire gauge. To change the dial setting, remove the lock pin and lift center of dial. Turn to the desired wire gauge. Replace lock pin on dial.

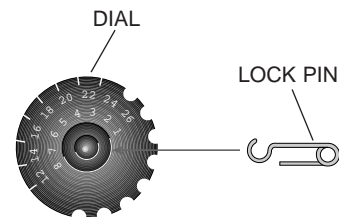

- Cycle the tool before inserting the contact to be sure the tool is in the open position. Drop the contact, mating end first, into the crimp cavity of the tool. Squeeze the tool handle just enough to grip the contact without actually crimping it.

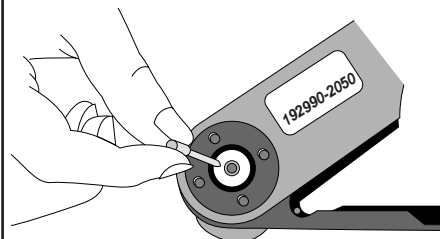

- Insert the stripped wire into the contact with a slight twisting motion. Be sure all wire strands are inside the contact. Squeeze the handle to cycle the tool. The handle will not release until the contact is completely crimped.

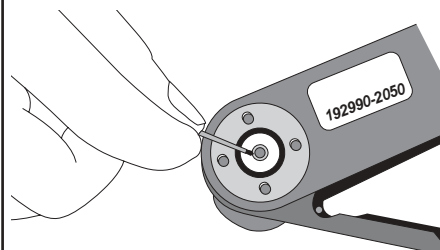

Crimp Tool Operation (continued)

- Remove the crimped contact. Pull on the wire slightly to be sure it is properly crimped. Be sure the contact is not bent or damaged in any way. Visually inspect the crimp:

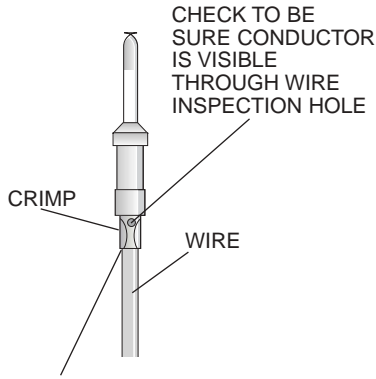

INSULATION SHOULD BUTT UP AGAINST THE END OF THE CONTACT.

MICRO SECTIONS

ENLARGEMENT OF MICROSECTION ALLOW FOR FINAL JUDGEMENT OF CRIMP QUALITY. THIS TEST IS RECOMMENDED WHENEVER NEW TOOLS OR NEW TYPES OF WIRE OR CONTACTS ARE USED.

Insertion of Contacts

- Slide the rear accessories over the wire bundle in the proper sequence for re-assembly: cable clamp and/or endbell first, then ferrule, and coupling nut.

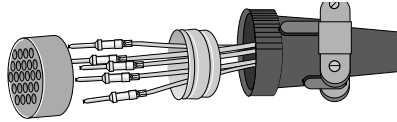

- Use the proper insertion tool from the Contact Selection Chart on [page 103](#). Place the contact in the tool. The tool should butt against the shoulder of the contact. Contact sizes 16S, 16, and 12 use a pliers style tool. Contact sizes 8, 4 and 0 use a tool with a 'C' shaped shaft.

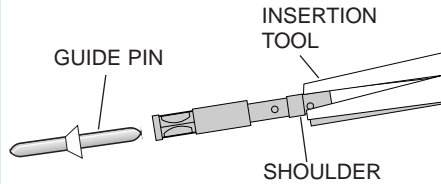

- Lubricate the grommet with isopropyl alcohol (do not use any lubricant other than isopropyl alcohol). Insert the contact through the appropriate cavity in the grommet. Sizes 16S, 16 and 12 SOCKET contacts must be installed using guide pins. See the Contact Selection Guide on page 103 for Insertion Guide Pin part numbers.

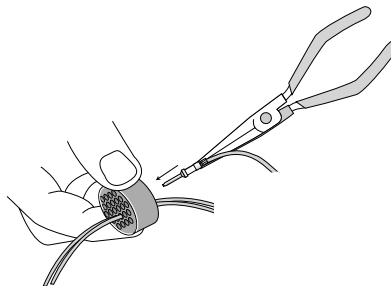

- Place the connector into an assembly fixture (fixtures are available for production use, call us.) If you are not using a fixture, be sure to allow clearance on the mating face of the connector for the guide pins to come through the connector during insertion.

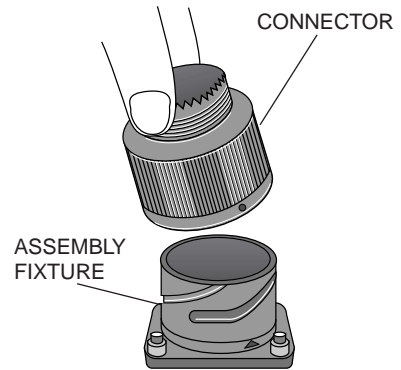

- Lubricate the contact cavities of the connector insulator with isopropyl alcohol (do not use any other type of lubricant).
- Using guide pins where necessary, push straight down with a firm even pressure until the contact snaps into position in the proper cavity. Start at the center of the pattern and work toward the outer edges.

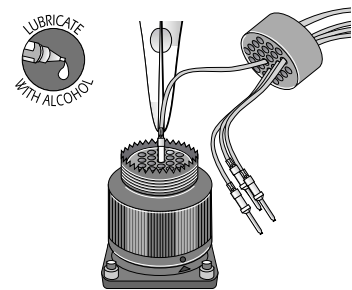

Assembly Instructions

Insertion of Contacts

7. Fill any unused cavities with contacts.

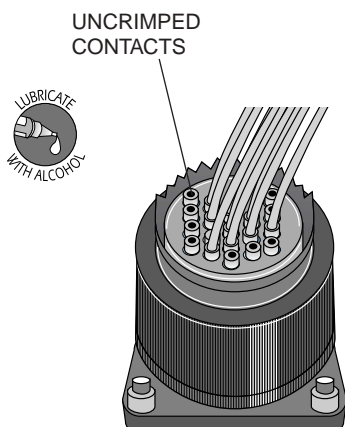

8. Check the mating face of the connector to insure that all the same size contacts are on the same plane (fully inserted). If not, the contact is not fully inserted. Remove the contact using the proper extraction tool and procedure and re-insert. Do not attempt to reinsert the insertion tool to correct the problem.



9. A wire hole filler must be inserted into the grommet behind the unused contacts to maintain the sealing integrity of the connector. See the Contact Selection Chart on page 103 for wire hole fillers.

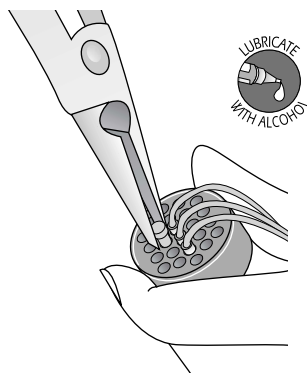

10. Place the connector back in the fixture for re-assembly. Slide the connector accessories back down the cable over the rear of the connector and tighten. Use the appropriate endbell tools as shown on page 266.

Extraction of Contacts

1. Remove the endbell accessories and slide them back over the wires. Use the appropriate endbell tools as shown on page 266.

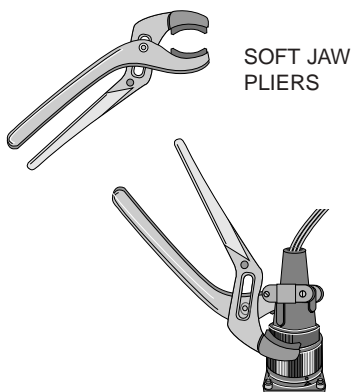

Extraction of Contacts (continued)

2. Use the proper extraction tool from the Contact Selection Chart on page 103. The extraction tool can be used for both pin and socket contacts by removing the shaft from the handle and reversing it for pin or socket extraction.

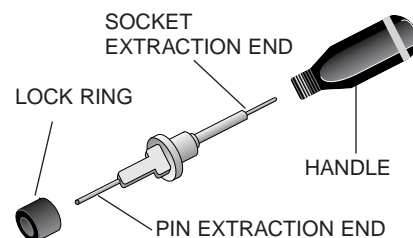

3. On the mating face of the connector, insert the tool over the pin contact or into the socket contact until the tool bottoms. Apply a slow continuous pressure to push the contact out the rear of the connector. When the shoulder of the tool "thunks" against the insulator, the contact is extracted.

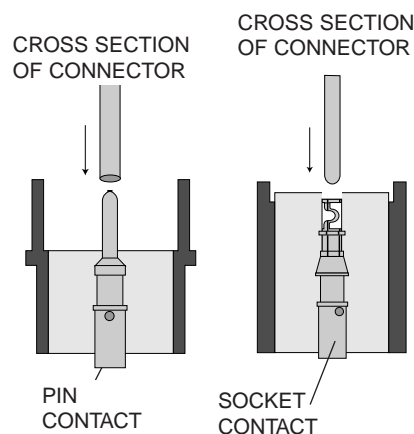

4. Carefully remove the extraction tool from the connector to avoid damage to the insulator.