

RECOMMENDED RETAINING RING
TRUARC N5000-56 OR EQUAL

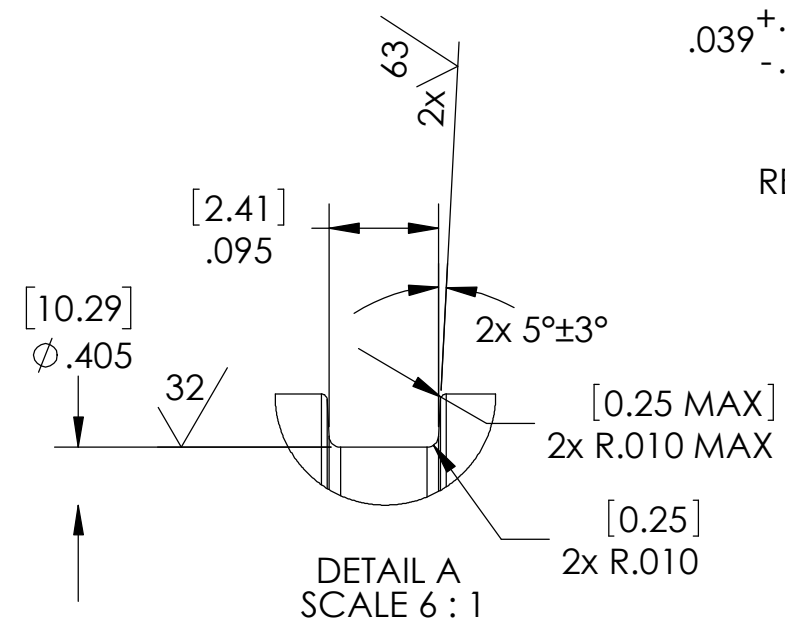

O-RING NOT SHOWN FOR CLARITY
BOTH GROOVES EQUAL EXCEPT WIDTH

- NOTES:
1. QUALIFICATION TESTS:
 - LEAK TEST: 150 PSI (AIR), NO BUBBLES 10 SECONDS MINIMUM.
 - HYPOT 1500 VAC, 0.5mA MAX LEAKAGE, 60 SECONDS MINIMUM, WIRE TO WIRE & INSTALLATION PORT.
 2. PRODUCTION TESTS:
 - LEAK TEST: 80 PSI (AIR), NO BUBBLES 10 SECONDS MINIMUM. A GREEN PAINT DOT INDICATES THE PART HAS PASSED THE LEAK TEST.
 - HYPOT 1000 VDC 100 MEGOHMS MINIMUM 0.01 SECONDS MINIMUM WIRE TO WIRE.
 3. ALL TESTS ARE PERFORMED AT ROOM TEMPERATURE.
 4. ALL PARTS MUST PASS ALL TESTS.
 5. COSMETIC SURFACE VOIDS NOT ON O-RING SEALING SURFACES ARE ACCEPTABLE BASED ON THE SEAL'S DIAMETER:
 - <= .5 [12.7] SEAL DIAMETER: ϕ .035 [8.9] MAX ALLOWED VOID SIZE
 - > .5 [12.7] SEAL DIAMETER: ϕ .060 [1.5] MAX ALLOWED VOID SIZE
 6. ENVIRONMENTAL SPECIFICATIONS (REFERENCE)
 - OPERATING TEMPERATURE -20°C TO 200°C.
 - STORAGE TEMPERATURE -40°C TO 200°C.
 7. REF-PARTS ARE DEFLASHED ON PARTING LINE +.005 [0.13] MAX.
 8. DIMENSIONS ARE INCHES [millimeters].
 9. CUT INSULATION PER DIMENSION SHOWN, IT IS ACCEPTABLE FOR 4X RETAINED ENDS (SLUGS) TO BE LOST DURING HANDLING.
 10. MEETS THE REQUIREMENTS OF IPC/WHMA-A-620, CLASS 2.

5	A/R	PARKER O-LUBE	LUBRICANT O-RING BARIUM BASED
4	2	-012 VITON	O-RING -012 VITON 75
3	1	EE18 BLACK	WIRE 18EE MIL-W-16878/5 .015
2	1	EE18 RED	WIRE 18EE MIL-W-16878/5 .015
1	A/R	PAVE-Seal 200UL94	EPOXY BLACK
ITEM	QTY	PART NUMBER	DESCRIPTION

2751 Thunderhawk Court
Dayton, OH 45414-3445
U.S.A.
tel (937) 890-1100
fax (937) 8905165
www.pavetechnologyco.com

PAVE technology co.

DESCRIPTION
SP8C-E-200UL94-2-TEE18-3-4

PART NUMBER
3578

MATERIAL NOTED

REVISION LEVEL
H

PROJECTION

ALL DIMENSIONS AND TOLERANCES APPLY TO FINISHED PART IN INCHES.
ALLOWABLE TOLERANCES UNLESS SPECIFIED OTHERWISE: NONE ±0.5
X.X DECIMAL ±0.1 X.XX DECIMAL ±0.02 X.XXX DECIMAL ±0.005
ANGLES ±1 DEGREE SURFACE FINISH 128 microinch RMS