

4900-3	TT24	CABLE T/C TYPE T 24AWG TEFLON	-200°C TO 125°C
4900-2	TT24 SLE	CABLE T/C TYPE T #24 TEF SPECIAL LIMITS OF ERROR	-200°C TO 125°C
4900-1	TT24 SLE	CABLE T/C TYPE T #24 TEF SPECIAL LIMITS OF ERROR	-20°C TO 125°C
4900	TT24	CABLE T/C TYPE T 24AWG TEFLON	-20°C TO 125°C
PAVE#	ITEM 3	ITEM 3 DESCRIPTION	TEMPERATURE

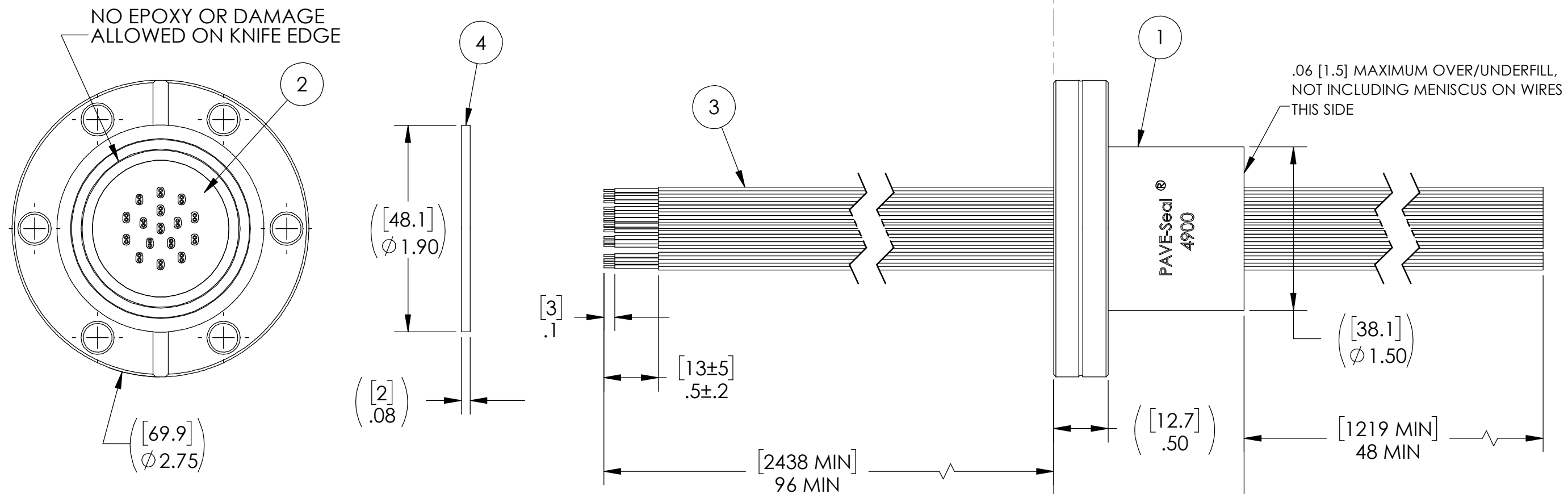

NOTES:

1. HE LEAK TEST @ 1 ATM. 1X10⁻⁷ CC/SEC OR LESS. LEAK TEST IS PERFORMED USING A G-275 VITON GASKET, A GREEN PAINT DOT ON THE ATMOSPHERE SIDE INDICATES THE PART HAS PASSED THE TEST.
2. HYPOT 630 VDC 500 MEGOHMS MINIMUM 0.01 SECOND MINIMUM WIRE TO WIRE AND HOUSING.
3. ALL TESTS ARE PERFORMED AT ROOM TEMPERATURE.
4. ALL PARTS MUST PASS ALL TESTS.
5. WIRE POSITIONING IS APPROXIMATE & VARIABLE.
6. COSMETIC SURFACE VOIDS NOT ON O-RING SEALING SURFACES ARE ACCEPTABLE BASED ON THE SEAL'S DIAMETER:
 <= .5 [12.7] SEAL DIAMETER: ϕ .035 [.89] MAX ALLOWED VOID SIZE
 > .5 [12.7] SEAL DIAMETER: ϕ .060 [1.5] MAX ALLOWED VOID SIZE
7. DIMENSIONS ARE INCHES [millimeters].
8. REF-OPERATING TEMPERATURE RANGE SEE TABLE.
9. PAVE-SEAL CAN BE A BI-DIRECTIONAL HERMETIC SEAL FOR VACUUM AND MOST PRESSURES. FOR PRESSURES ABOVE 150 PSI (10 BAR), CHECK WITH SALES ENGINEERING.

4	1	GASKET G-275 C	GASKET COPPER
3	16	SEE TABLE	SEE TABLE
2	A/R	PAVE-Seal 150	EPOXY BLACK
1	1	5610	HOUSING CF275-SS
ITEM	QTY	PART NUMBER	DESCRIPTION

PAVE technology co.
 2751 Thunderhawk Court
 Dayton, OH 45414-3445
 U.S.A.
 tel (937) 890-1100
 fax (937) 8905165
 www.pavetechnologyco.com

DESCRIPTION
 CF275-SS-150-16P-TT24-96-48

PART NUMBER
4900

MATERIAL NOTED

REVISION LEVEL
 C

PROJECTION

ALL DIMENSIONS AND TOLERANCES APPLY TO FINISHED PART IN INCHES.
 ALLOWABLE TOLERANCES UNLESS SPECIFIED OTHERWISE: NONE ±0.5
 X.X DECIMAL ±0.1 X.XX DECIMAL ±0.02 X.XXX DECIMAL ±0.005
 ANGLES ±1 DEGREE SURFACE FINISH 128 microinch RMS