

**NOTES:**

1. HE LEAK TEST @ 1 ATM. 1X10<sup>-8</sup> CC/SEC OR LESS. A GREEN PAINT DOT ON THE ATMOSPHERE SIDE INDICATES THE PART HAS PASSED THE TEST.
2. HYPOT 630 VDC 500 MEGOHMS MINIMUM 0.01 SECOND MINIMUM WIRE TO WIRE AND HOUSING.
3. ALCOHOL OR FOMBLIN YVAC 3 MAY BE USED TO LUBRICATE O-RINGS FOR VACUUM HELIUM LEAK TESTING.
4. ALL TESTS ARE PERFORMED AT ROOM TEMPERATURE.
5. ALL PARTS MUST PASS ALL TESTS.
6. WIRE POSITIONING IS APPROXIMATE & COLOR POSITIONS ARE VARIABLE.
7. COSMETIC SURFACE VOIDS NOT ON O-RING SEALING SURFACES ARE ACCEPTABLE BASED ON THE SEAL'S DIAMETER:  
 <= .5 [12.7] SEAL DIAMETER:  $\phi$ .035 [.89] MAX ALLOWED VOID SIZE  
 > .5 [12.7] SEAL DIAMETER:  $\phi$ .060 [1.5] MAX ALLOWED VOID SIZE
8. REF-OPERATING TEMPERATURE RANGE -20°C TO 125°C.
9. DIMENSIONS ARE INCHES [millimeters].
10. PAVE-SEAL CAN BE A BI-DIRECTIONAL HERMETIC SEAL FOR VACUUM AND MOST PRESSURES. FOR PRESSURES ABOVE 150 PSI (10 BAR), CHECK WITH SALES ENGINEERING.

9	1	0102	NUT VS32-SS
8	1	-231 VITON	O-RING -231 VITON 75
7	6	EE10 ORANGE	WIRE 10EE MIL-W-16878/5 .017 37/#26
6	7	EE10 WHITE	WIRE 10EE MIL-W-16878/5 .017 37/#26
5	7	EE10 RED	WIRE 10EE MIL-W-16878/5 .017 37/#26
4	6	EE10 GREEN	WIRE 10EE MIL-W-16878/5 .017 37/#26
3	7	EE10 BLACK	WIRE 10EE MIL-W-16878/5 .017 37/#26
2	A/R	PAVE-Seal 150	EPOXY BLACK
1	1	0101	HOUSING VS32-SS
ITEM	QTY	PART NUMBER	DESCRIPTION

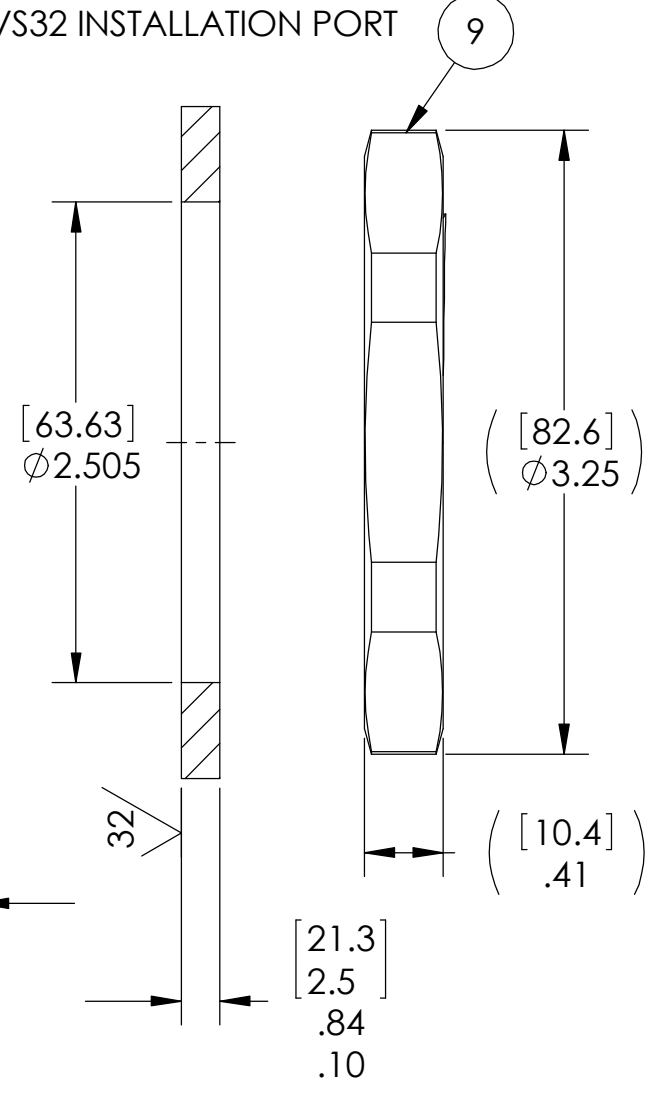

ALL DIMENSIONS AND TOLERANCES APPLY TO FINISHED PART IN INCHES.  
 ALLOWABLE TOLERANCES UNLESS SPECIFIED OTHERWISE: NONE ±0.5  
 X.X DECIMAL ±0.1 X.XX DECIMAL ±0.02 X.XXX DECIMAL ±0.005  
 ANGLES ±1 DEGREE SURFACE FINISH 128 microinch RMS

**PAVE technology co.**  
 2751 Thunderhawk Court  
 Dayton, OH 45414-3445  
 U.S.A.  
 tel (937) 890-1100  
 fax (937) 8905165  
 www.pavetechnologyco.com

DESCRIPTION  
 VS32-SS-150-33-TEE10-120-120

PART NUMBER <b>5821</b>	MATERIAL NOTED
REVISION LEVEL C	PROJECTION ☉ ◻